

## Self-Driven Transporting Vehicle for Institutional Campus Mobility: Design and Development of an Autonomous Shuttle System for Safe and Efficient Transportation

Prof. Aisha Khan<sup>1</sup>

<sup>1</sup> ETH Zurich, Department of Autonomous Systems and Intelligent Mobility Engineering, Zurich, Switzerland

### ABSTRACT

Now a day's pollution and global warming is one of the major problems that our state faces, the main reason for this is vehicles that run by burning oil. This paper presents a unique embedded controller design of a driverless, solar energy powered, collision protected, and GSM destination guided vehicle. The energy required for the movement of vehicle has been derived through solar PV power [4] which is green in nature. It doesn't pollute the environment. A GPS module [2] accurately tracks the location of the vehicle. Source and destination details are getting from the SMS sent by the user from his mobile phone. The navigation process includes localization, obstacle detection, and path planning and vehicle control. The ultrasonic sensor senses the obstacle in the path and prevents collision due to the obstacle. This vehicle is capable of sensing its current status and navigating without human input.

**KEYWORDS:** Driverless; Location tracking using GPS; Obstacle detection using ultrasonic sensor; Passenger detection; Communication by GSM; Solar power.

---

### 1. INTRODUCTION

Different academic blocks in the campus of an educational institution will usually be at certain distance apart. Usually it consumes much amount of time to travel between these academic blocks. A transporting vehicle which is fully automatic and environment friendly can solve this problem. This paper proposes a system that uses solar power for the movement of the vehicle, solar power is green in nature. This system presents a unique embedded controller design of a driver less, solar energy powered, collision protected and GSM destination guided vehicle. It is capable of sensing the obstacle and navigation without human input. In this system the GSM module is used to communicate between the user and the vehicle. Arduino Mega micro controller is used for making the system fully functional prototype. Pressure sensor is used for sensing the presence of user in the vehicle. The location tracking process is carried out by GPS module. The navigation process includes localization, obstacle detection, and path planning and vehicle control.

### 2. WORKING

The automatic vehicle is capable of sensing the present location, user location and navigates by the help of integrated GPS mapping [5]. The solar panel that is mounted on the roof of the vehicle helps to power up the system. In between the solar panel and the battery there is Maximum power point tracking unit (MPPT) [10] which is used for extracting maximum power from the panel. The GSM module is used to send SMS to the system. An ultrasonic sensor is used to detect the obstacle in its path, the path for the vehicle is already programmed in Arduino Mega. The ultrasonic sensor works when vehicle is moving, which helps the vehicle to reach the destination by avoiding obstacle. The movement of the system is controlled by the voltage fed to the motor by H Bridge IC L293D. It controls the wheels according to the program based on the response of sensors. The pressure sensor senses the presence of user in the vehicle. The system frequently checks the value of the pressure sensor output.

### 3. BLOCK DIAGRAM

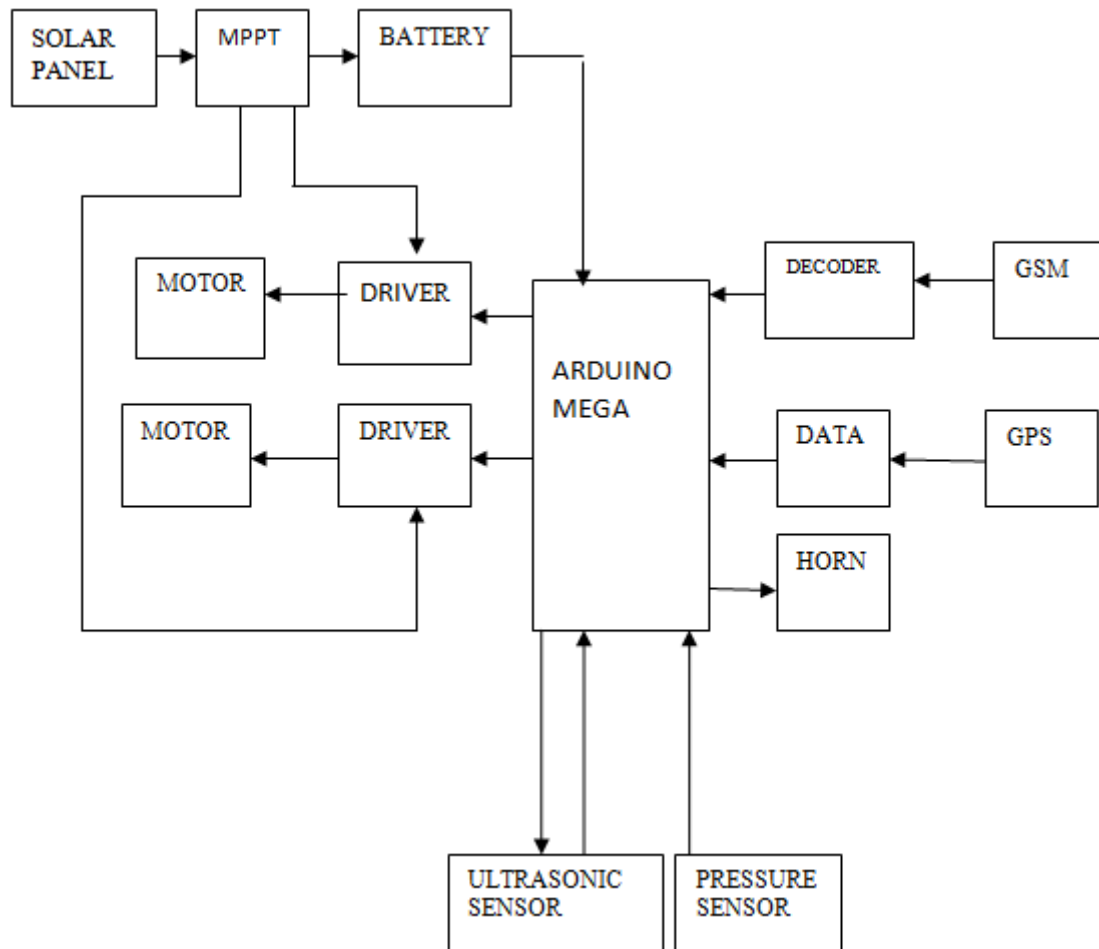

### 4. COMPONENTS

#### A) ARDUINO MEGA

The Arduino Mega2560 is a microcontroller board based on the ATmega2560; it has 54 digital input output pins, 16 analog inputs, 4 UARTs and a 16 MHz crystal oscillator. It also consists of a power jack and USB port for powering up the Arduino. The power source is selected automatically. The operating voltage of Arduino Mega is 5V but the recommended voltage is 6 to 20 volts. If the supply is less than 7V, the 5V pin may supply less than five volts and the board may be unstable. If it is more than 12V, the voltage regulator may overheat and damage the board. The recommended range is 7 to 12 volts. It has 256KB of flash memory for storing code, 8 KB of SRAM and 4 KB of EEPROM. The Arduino Mega can be programmed in Arduino IDE platform. The ATmega2560 on the Arduino Mega contains an in builtboot loader that allows to upload new code to it without the use of an external hardware programmer. Its communication is based on original STK500protocol.

#### B) LOCATION TRACKING

The Global Positioning System (GPS) is a satellite basedradio navigation system. It is the system which shows the exact position on earth at any time in any weather conditions. It requires an unobstructed line of sight path for communication. It contains three segments, space segments, control segment, user segment. The space segment includes 24 satellites arranged in 6 orbital planes inclined 55 °with respect to equator. Control segment includes master control stations, alternate master control station and 6 monitoring stations. User segment consist of earth based GPS receiver. The system uses NEO-6M GPS receiver, it has high resolution about 2.5m. Its antenna provides strong satellite search capability.

#### C) MPPT

**MPPT** or **Maximum Power Point Tracking** [3] is a charge controllers used for extracting maximum available power from PV (photo voltaic) module under certain conditions. The voltage at which PV module can produce maximum power is called ‘maximum power point’ (or peak power voltage). Maximum power varies with

intensity of sunlight, ambient temperature and temperature of the solar cell. It reduces the complexity of the system and yields high efficiency.

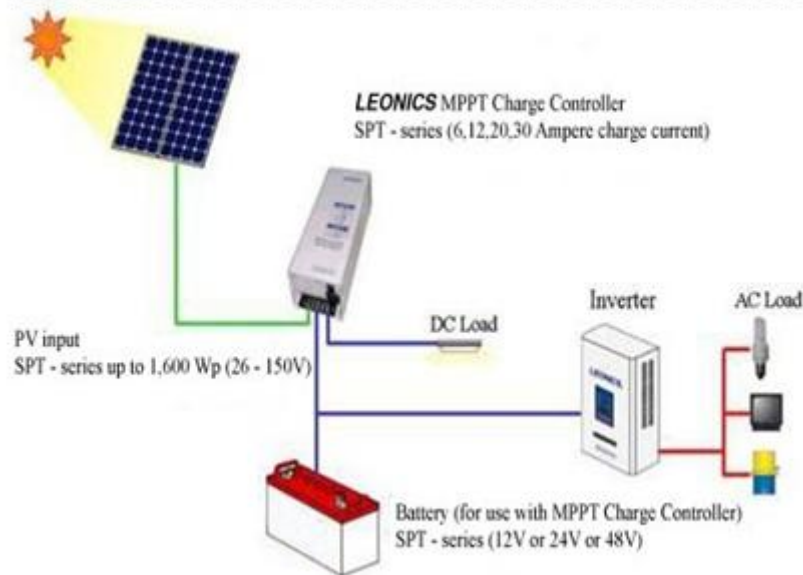

**Figure1: MPPT**

## D) OBSTACLE DETECTION

An Ultrasonic sensor is a device that can measure the distance [10] to an object by using sound waves. It measures distance by sending out a sound wave at a specific frequency and listening for that wave to bounce back. The wave travels through air at about 340 m/s. The time taken for the wave to return is multiplied with the speed to get the round trip distance. Round-trip means that the sound wave traveled 2 times, from the sensor to the object and from the object to the sensor. To find the distance to the object, simply divide the round-trip distance by two.

## E) USER IDENTIFICATION

Pressure sensor is a type of pressure transducer used to detect the presence of user in the vehicle. It is a sensing element of constant area and respond to force applied to this area by fluid pressure. When a force is applied to the pressure transducer, the diaphragm deflects and it can be measured and converted it into an electrical output.

## F) MESSAGING

Global system for mobile communication (GSM) is used for the communication purpose. It is a device which can be either a mobile phone or a modem device which can be used to make a computer or any other processor to communicate over a network. A GSM modem requires a SIM card to be operated and operates over a network range subscribed by the network operator. It can be connected to a computer through serial, USB or Bluetooth connection. The user sends an SMS regarding the need of the vehicle. This system uses SIM900, because it can Control via AT commands and consumes less power.

## G) LOCOMATION AND ROTATION

The movement of the vehicle [10] is controlled by the DC motor and whose speed is controlled by the DC voltage fed to the motor. The system uses four DC motors with motor drivers to control four wheels of the vehicle. The shaft encoder can count the number of pulse output during rotation in the positive direction and reverse direction and this rotation counts are not limited. It is also used for determining the angular position of a rotating shaft. According to the rotation, it generates an electrical signal, either analog or digital.

## 5. FLOW CHART

# Metal Ions in Life Sciences

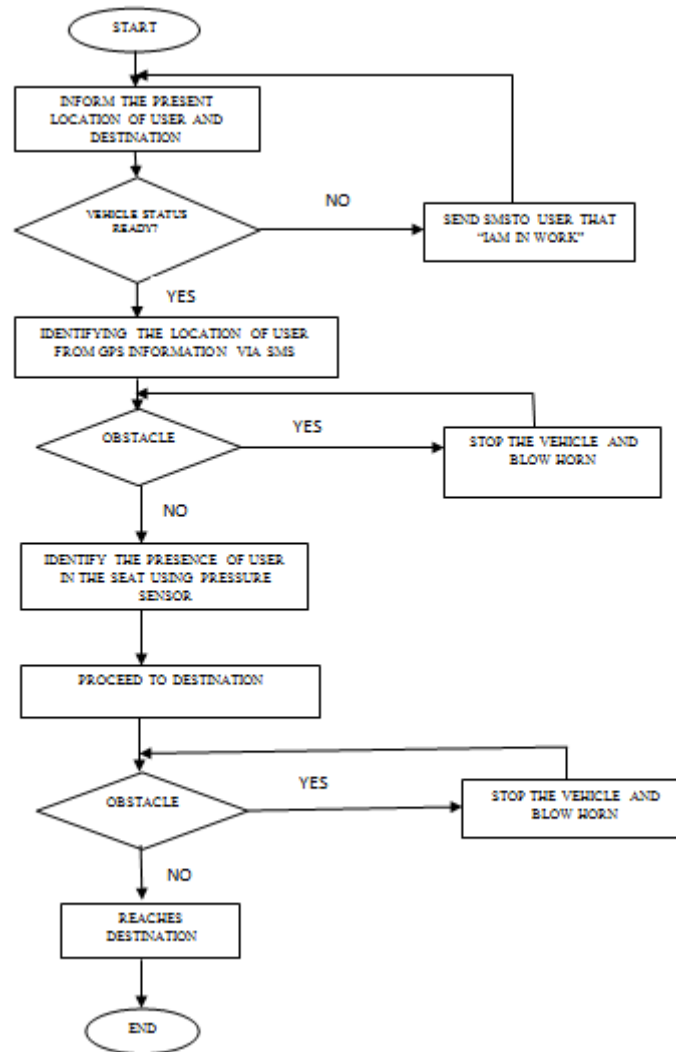

Figure2: Flow chart of the process.

## STEPS

1. If the user wants to go to a particular place, go to step2
2. User sends SMS to the system regarding the information of present location and the destination
3. System frequently checks the vehicle status
4. If the vehicle is engaged in a work, it sends a SMS to the user that” I AM IN WORK”
5. If the vehicle is free, it identifies the user location from the GPS information via SMS
6. On the way, it senses the presence of obstacle
7. If there is an obstacle, stops the vehicle and make horn
8. If there is no obstacle, proceed to the destination.

## 6. ADVANTAGES

The system uses renewable source of energy instead of fossil fuel thus it reduces the emission of carbon dioxide and other greenhouse gases. It also helps to prevent the scarcity of fossil fuels in future. Therefore, the amount of pollution is considerably reduced. Now a day the number of accidents in roads are due to careless driving. The proposed system efficiently controls the accident. This system can be used without driving license. Passengers would be able to travel overnight and sleep for the duration. The sensors used in the system can able to detect large and small objects.

## 7. DISADVANTAGES

If the application of the system is extended to road transportation, it may badly affect the employment of taxi drivers. Driver less cars will be costly for ordinary people when it is newly introduced in the market. Driverless cars would be great news for terrorists, as they can load explosive materials, other attacking devices and used as moving bombs. This computerized system is difficult to understand human hand signals.

## 8. FUTURE SCOPE

After further modification, the system can be used similar to a Google car. It can be used for the travel of disabled persons in airports. It can be used to travel in golf clubs and highly useful in supplying drinks in sports. In tourist centers this system can be used as a transporting vehicle for sightseeing over a wide area.

## 9. CONCLUSION

The functionality of the system is divided into obstacle detection, messaging, user identification and location tracking. The proposed system can overcome the transportation problems associated with in an institution campus. This system is an efficient and flexible method for interactive transportation. It can be used as a real time transporting vehicle in future.

## 10. ACKNOWLEDGEMENT

We would like to express our gratitude to KSCSTE (Kerala State Council for Science, Technology and Environment) for providing the fund for realizing the work and also like to express our gratitude to all the teaching and non-teaching staffs of College of Engineering, Karunagappally for their whole hearted support and for providing us with the necessary infrastructure. We also like to express my sincere thanks to Dr.Jaya.V.L, the Principal of the college for her kind support for the progress of our work. Special thanks to the Head of the Department of Electronics and Communication Engineering, Dr.Gopakumar.C for proper guidance and encouragement. Last but not the least we are grateful to my friends and parents for their valuable support and motivation.

## REFERENCES

- [1] Yu.C, Hang's, Lang.Y., "Traffic Light Detection During Day and Night Conditions by a Camera", 978-1-4244-5900-1/10©2010 IEEE.
- [2] Parthasarathy.J., "Positioning And Navigation System Using GPS", International Archives of the Photogrammetry, Remote Sensing and Spatial Information Science, Volume XXXVI, Part 6, Tokyo Japan 2006.
- [3] Kotak V.C,Tyagi P., "DC to DC Converter in Maximum Power Point Tracker", IJAREEIE, e-ISSN: 2278-8875, p-ISSN: 2320-3765, Volume 2, Issue 12.
- [4] Bharathi V.V. P., PandurangaduV,Deepthi V.V.N., "Car Runs By Solar Energy", ISSN 2278 – 0149, IJMERR, Vol. 4, No. 1, January2015.
- [5] Mohanapriya R., Hema L.K., Yadav D., Verma V.K., "Driverless Intelligent Vehicle for Future Public Transport Based On GPS", International Journal of Advanced Research in Electrical, Electronics and Instrumentation Engineering, Vol. 3, Special Issue 3, April 2014.
- [6] L.Todd., "Autonomous Vehicle Implementation Predictions", Presented at the 2015 Transportation Research Board Annual Meeting (www.trb.org), 15- 3326.
- [7] M., Michael A. Regan M.A., "Autonomous Vehicles: Human Factors Issues and Future Research", Proceedings of the 2015 Australasian Road Safety Conference 14 - 16 October, Gold Coast, Australia.
- [8] Sharma P., Verma P., Pal A.," Electrical Designing Of Solar Car", International Journal of Electronics, Electrical and Computational System IJEECS ISSN 2348-117X Volume 3, Issue 3 May 2014.
- [9] Balamurugan T.,Manoharan S., "Design of Solar/Electric Powered Hybrid Vehicle (SEPHV) System with Charge Pattern Optimization for Energy Cost", International Journal of Engineering and Technology (IJET) ISSN : 0975-4024 Vol 5 No 6 Dec 2013-Jan 2014.
- [10] T.Banerjee., S.Bose., A.Chakraborty.,T.Samadder.,Bhaskar Kumar.,T.K.Rana.,"Self-Driving Car: A Peep into the Future",978-1-5386-2215-5/17/\$31.00©2017 IEEE